



Ocean Engineering Considerations for Ocean Renewable Energy

WHAT WE DO

PRODUCT LINES

HardSuits
ATMOSPHERIC
DIVING SYSTEMS



SubWorks
SUB RESCUE
SYSTEMS



OceanTools
REMOTE TOOLING
SYSTEMS



Special Projects



Many factors must be considered and multiple Engineering disciplines are required to bring Ocean Renewable Energy into the mainstream

ENVIRONMENTAL CONDITIONS

Ocean Renewable Energy Systems must be designed to effectively operate in the environment where they are deployed

LOADS TO BE CONSIDERED

- Water Current
- Waves
- Wind
- Ice
- Thermal
- UV Radiation
- Pressure



SYSTEM DESIGN, INTEGRATION, AND TEST

Many advanced and traditional tools are available to design, model, fabricate and test effective systems

STRUCTURAL

- Finite Element Analysis (FEA)
- 3D Computer Aided Design (CAD)
- Load testing
- Scale model testing

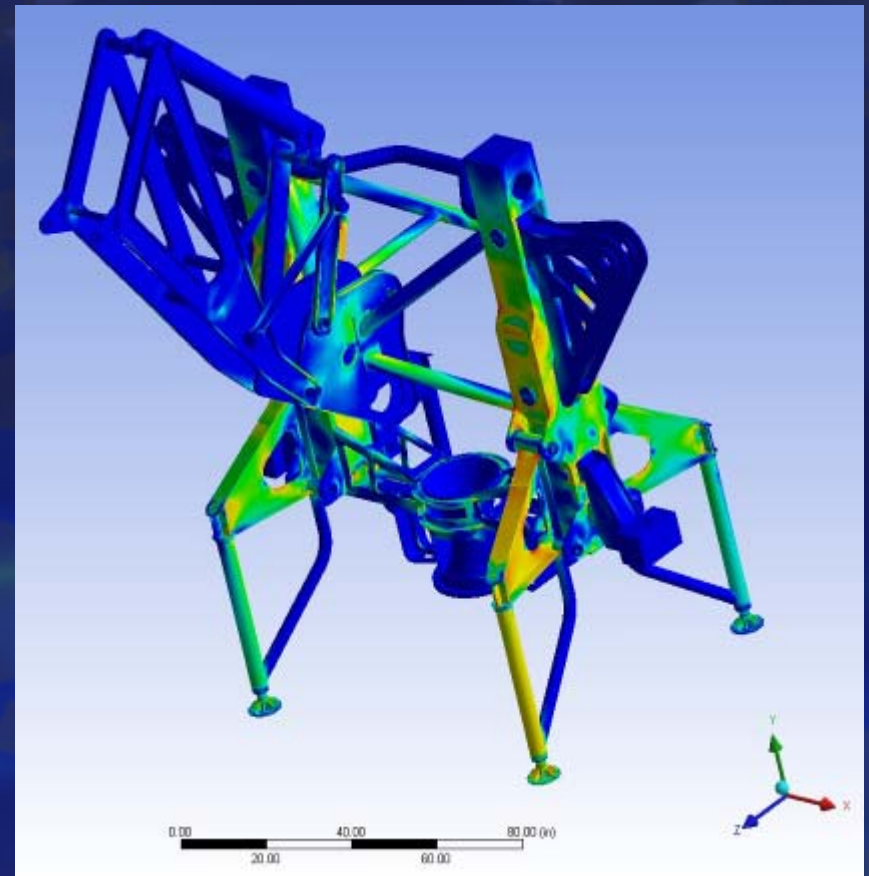

HYDRODYNAMIC

- Computational Fluid Dynamics (CFD)
- Wave, wind, and current testing on scale models and prototypes

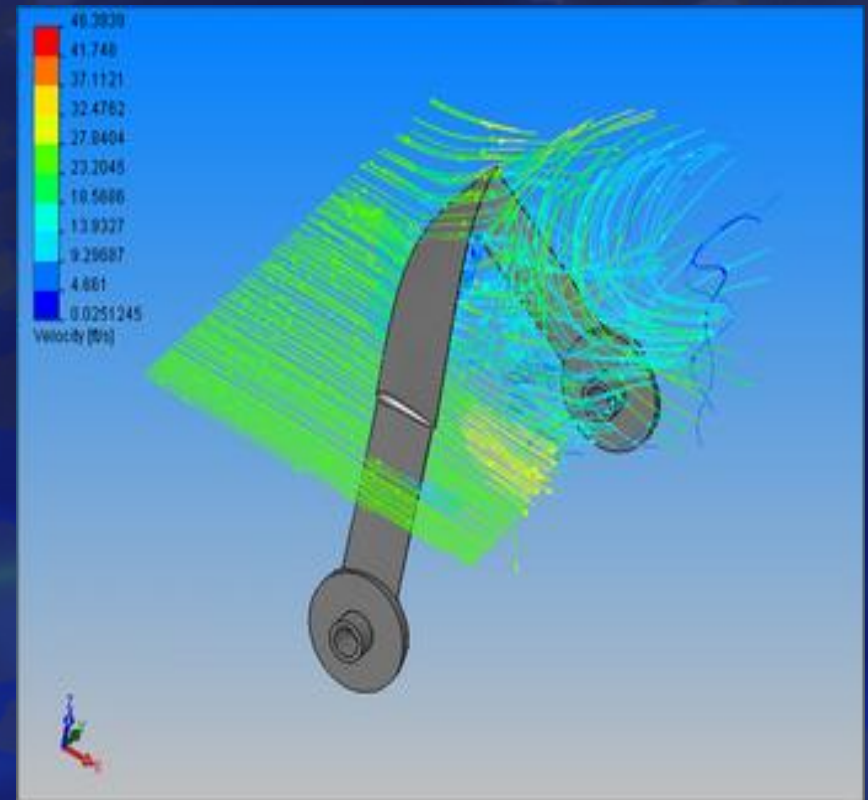

MECHANICAL

- 3D Computer Aided Design (CAD)
- Dynamic modeling
- Cyclic testing

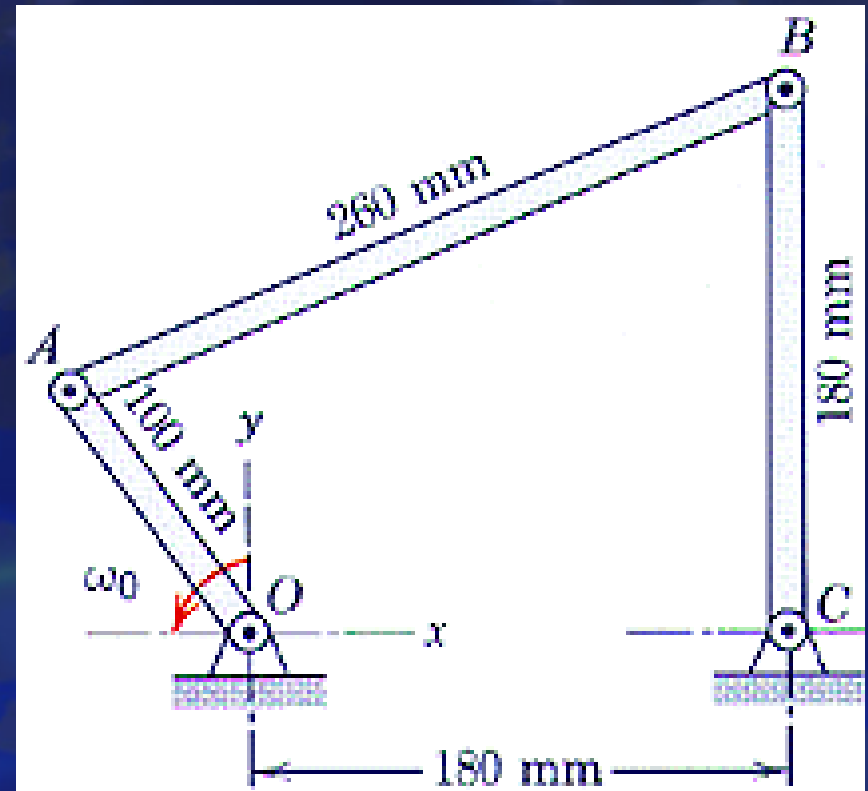

ELECTRICAL

- Marinizing electrical and electronic components can be challenging
- Ocean Renewable Energy can leverage the lessons learned in other ocean industries



CORROSION

Major forms

- General
- Galvanic
- Pitting
- Crevice
- Stress cracking
- Intergranular



CORROSION

Prevention

- Material Selection
- Cathodic protection
- Coatings

Issues

- Cost
- Availability
- Manufacturability
- Limited Applicability
- Maintenance



BIOFOULING

- Known problem
- Site specific
- Increases weight
- Increases drag
- Reduces flow path
- Incapacitates sensors



BIOFOULING

Prevention/Treatment

Issues

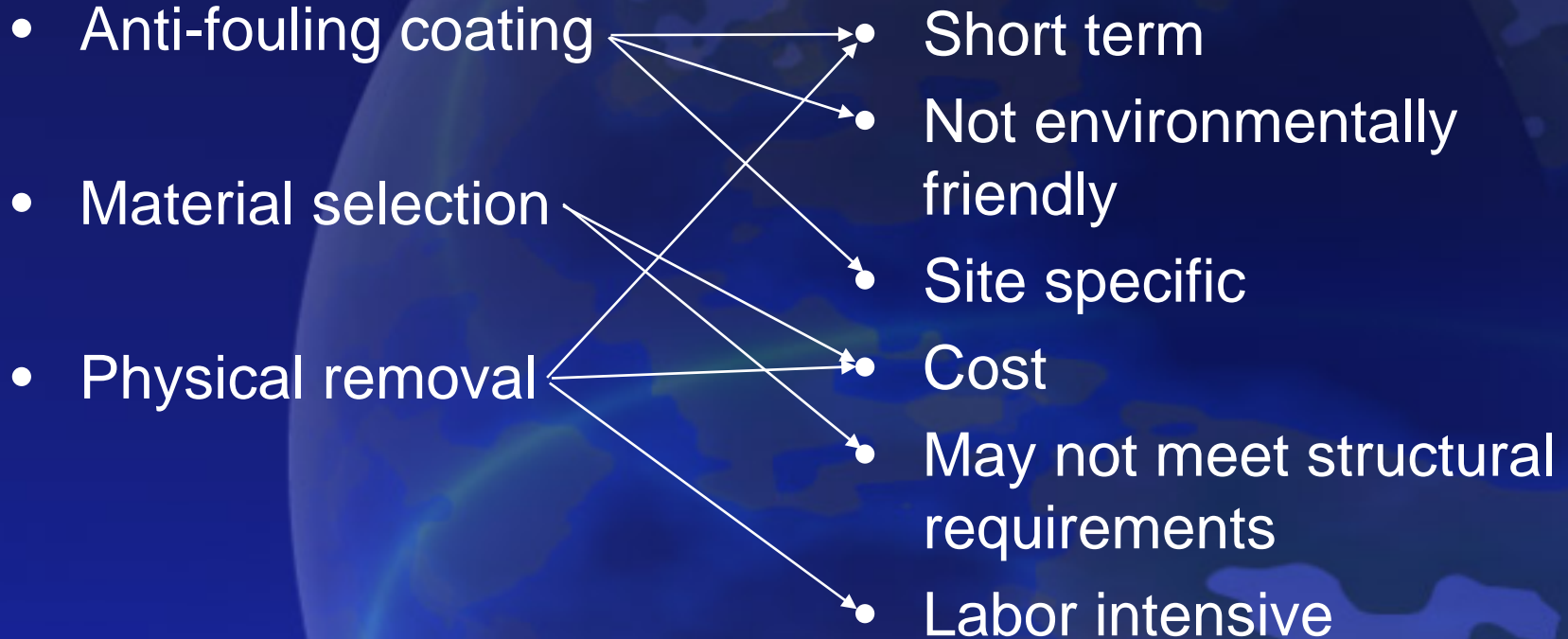

FABRICATION

- Shipyards
- Industrial fabricators
- Machine shops
- High specification specialty fabricators



INTEGRATION

Ocean Renewable Energy requires the integration of many disparate attributes

- Shipyards
- System Integrators
- Multidisciplined
- Integrated Testing
- Certification





IT'S BUILT, NOW WHAT?

INSTALLATION

- The nature of Ocean Renewable Energy is that we require the structures to be placed in harm's way
- To access these areas can require large, specialized equipment



TRANSMISSION

Ocean Renewable Energy Devices require methods to get the energy to shore

- Subsea power cables are a fairly mature industry
- Originally developed for telecommunications and utilities

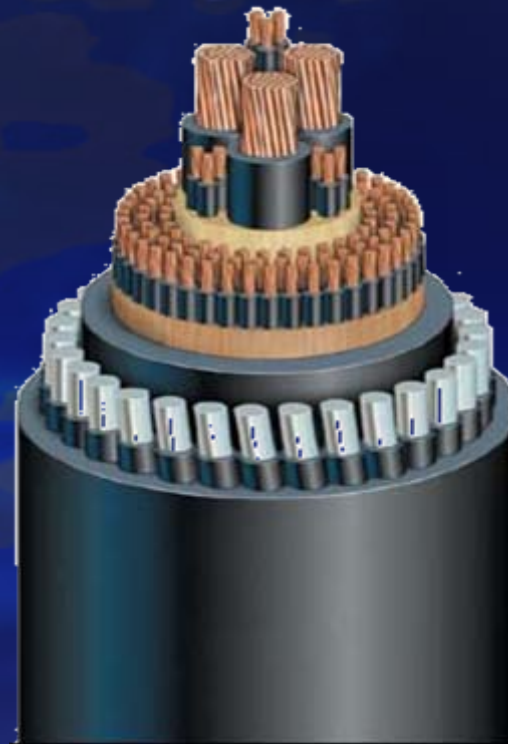

MONITORING

- Most Ocean Renewable Energy Devices are remote to the operators
- Sensors monitor the systems in real time
- Shore stations monitor the sensors and provide remote control

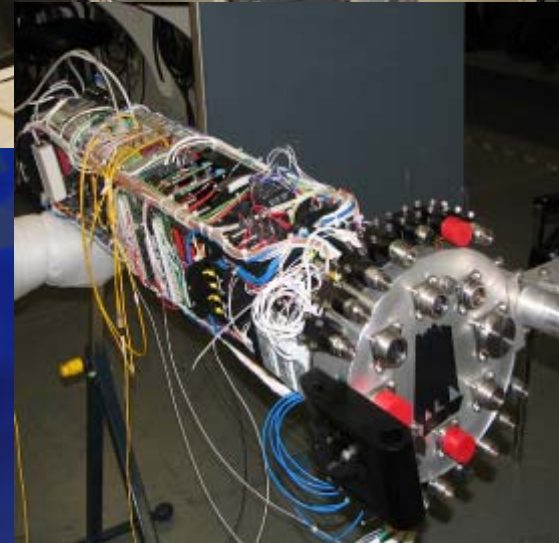

ENERGY STORAGE OR CONVERSION

If no grid connection is available, other system components are required to smooth out intermittent delivery

- Batteries
- Water Storage
- Pressurized Air
- Desalination
- Diesel Backup



MAINTENANCE

- Once the system is installed and operating we have to be able to maintain it
- Maintenance must be part of system design so that intervention is cost effective



ENVIRONMENTAL IMPACT

Everything we do affects the environment we live in

- Site specific
- Wave and current patterns
- Animal and plant life
- Human interaction
- End of life





THANK YOU