

# OceanWorks International

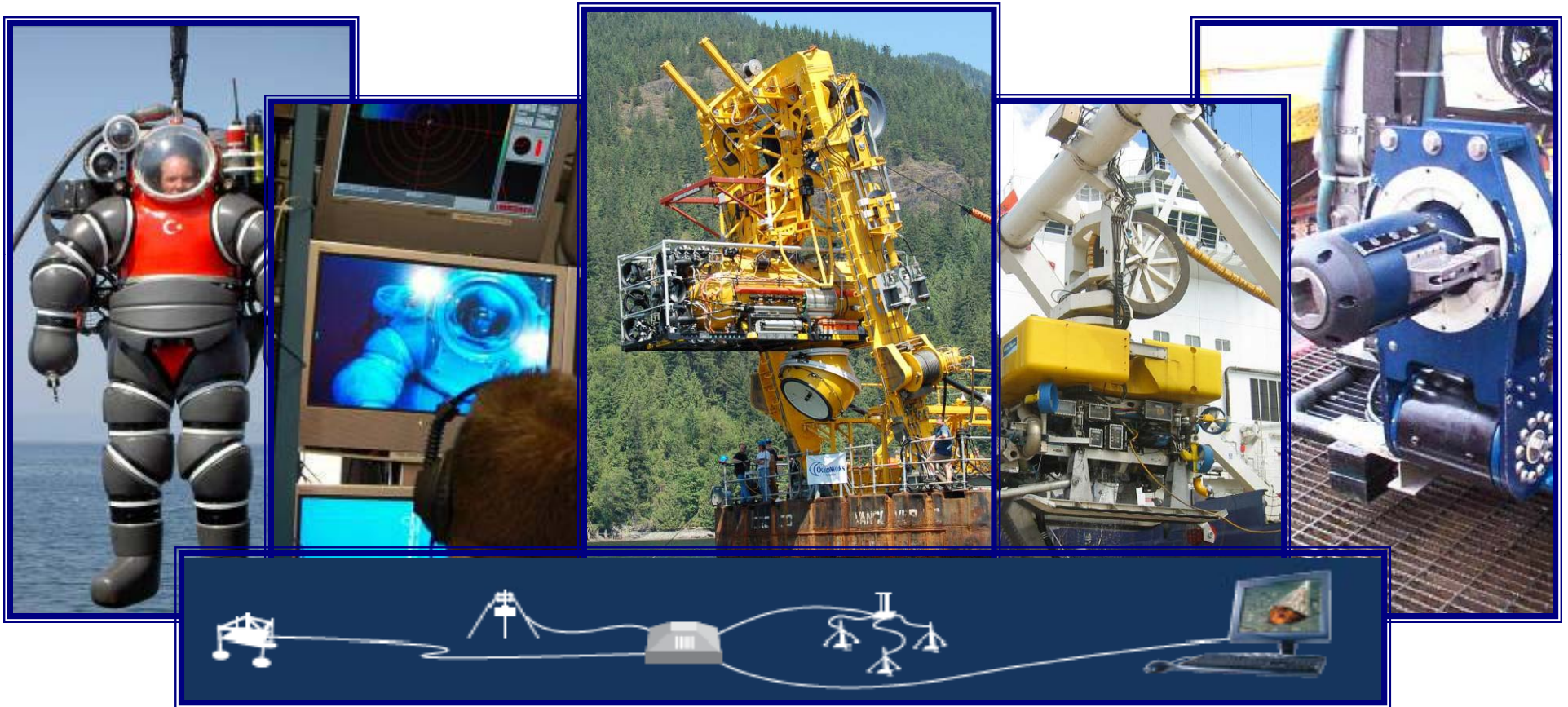

## Network Control of Ocean Renewable Energy Systems

# Introduction

- **OceanWorks International (OWC) is a leading supplier of specialized subsea products and services:**
  - Atmospheric Diving Systems
  - Submarine Rescue Systems
  - Subsea Cabled Observatories
  - Remote Intervention Tooling
  - Field Development Hardware
  - Engineering, Fab. & Tech. Services
- **Markets served:**
  - International Military
  - Scientific / Environmental
  - Renewable Energy
  - Oil & Gas
  - Salvage & Construction
  - Submarine Telecom
- **Facilities located in Houston, TX and North Vancouver, B.C.**
  - ~ 145 Employees: 45 in the U.S., 100 in Canada

# What is being done today to Control and Monitor Ocean Renewable Energy Devices

- Companies are using custom solutions based on Industrial Ethernet and/or PLC's

or

- They are not this far along in their programs yet

# Purpose of this Presentation

- To show how a commercial technology that has been developed over the last number of years can be used to control and monitor any ocean renewable energy device
- To show how this same technology can be used to monitor the environment around ocean renewable energy devices

# Historical Deployment of Ocean Instrument Packages

- Battery powered single or multiple instrument packages on the seafloor
  - Low sampling rate/bandwidth
  - Low power
  - Limited duration
  - No real time control or data
- Solar and/or battery powered buoys with surface and subsea instruments
  - Low sampling rate/bandwidth
  - Low power
  - Real time control and data
  - Limited availability due to environmental conditions



# Subsea Cabled Observatories

- Most early deployments were custom solutions with dedicated sets of instruments
- Second generation (Bonne Bay, LEO-15) were designed to be more generic and use a variety of off the shelf instruments
- Other types of offshore deployments are custom PLC based with limited flexibility and monitoring capabilities

# Recent Generation (past 3 years)

- Multiple nodes
- Multiple junction boxes per node
- Multiple instruments per junction box
- Gigabit Ethernet backbone
- Interface can be used with virtually any instrument
- 20 year design life
- Always available
- High power
- Redundancy
- Reliability
- Extensive testing and qualification
- Extensive diagnostic capability
- Modular



**VENUS Node**

# VENUS Architecture

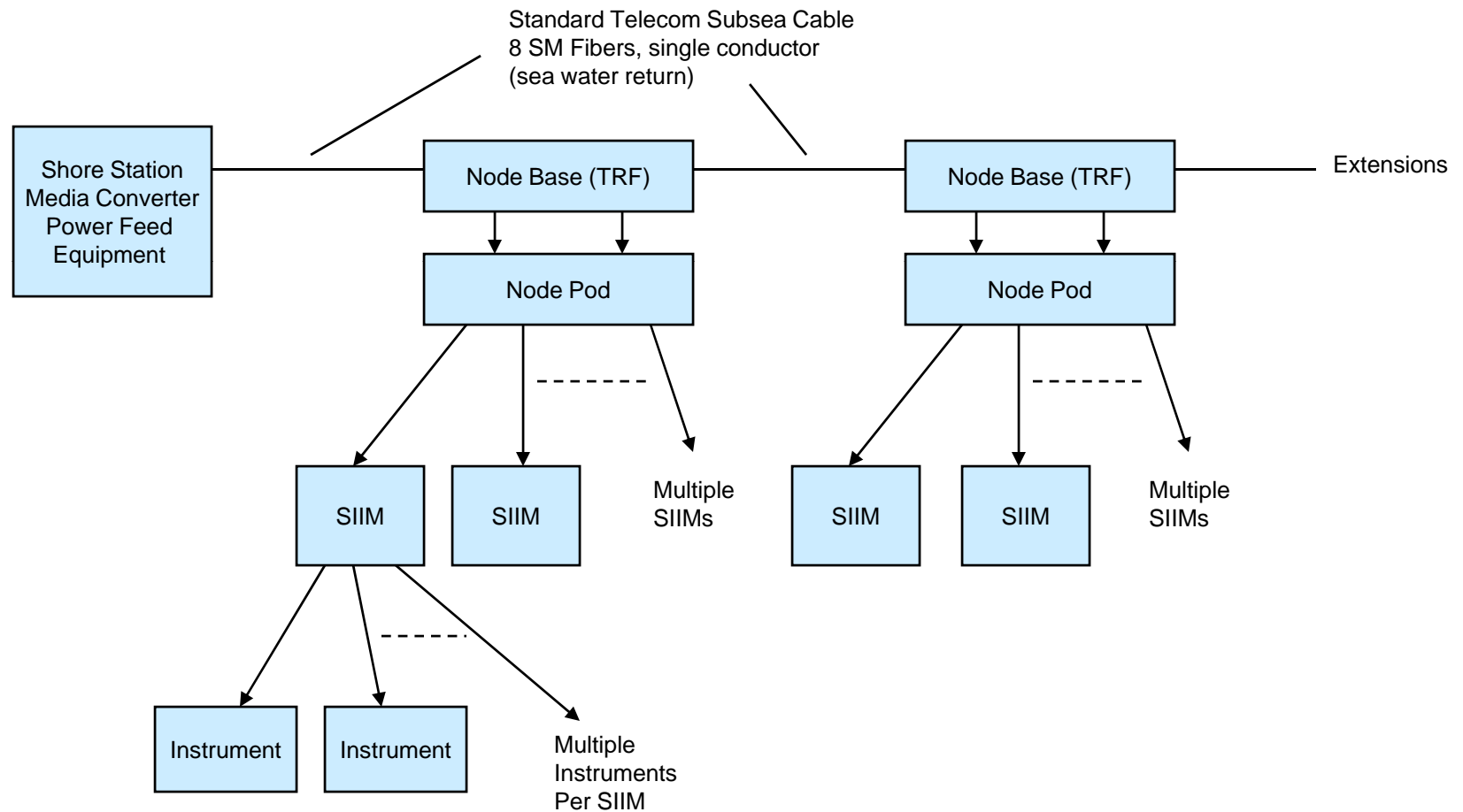

# Current and Future Generation (being deployed now)

- NEPTUNE Canada (backbone already installed, junction boxes built and tested)
- MARS (backbone already installed)
- OOI
- ESONET
- Others being planned

# Features of Current and Future Generation

- Increased levels of redundancy and reliability
- Deeper water (3000m)
- Higher Power (100kW)
- Higher Voltage (10kVDC)
- 10 Gigabit Ethernet
- More instruments per junction box
- Longer distances (800km)

# Topology of a Subsea Cabled Observatory

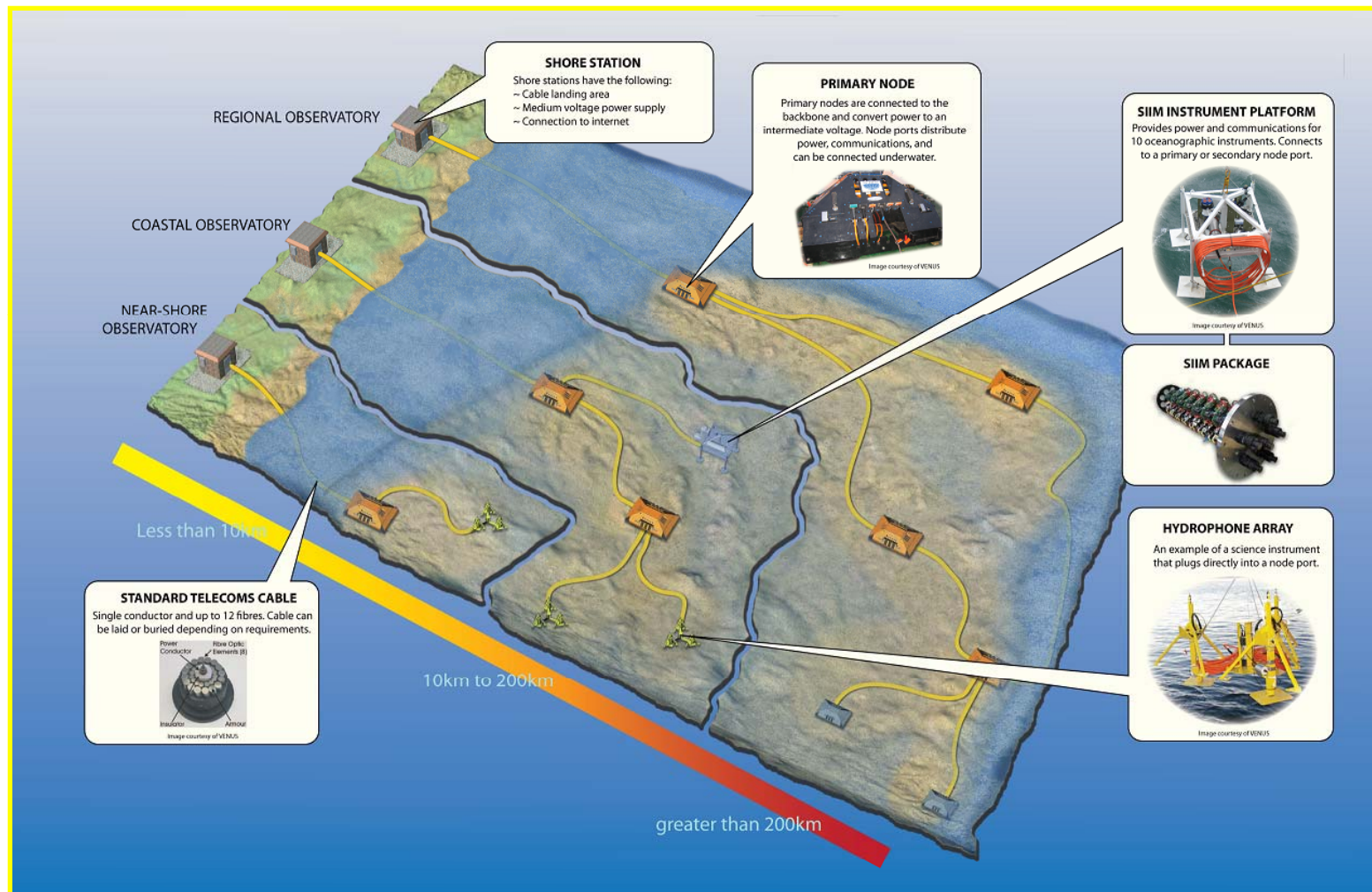

# OceanWorks Cabled Observatory History

- OceanWorks is a world leader in cabled observatory technology
- OceanWorks developed and built the first Pacific coast cabled observatory to enter full service, VENUS Saanich Inlet. The Saanich Observatory consists of 1 Node and 3 SIIMS. The Saanich Inlet observatory has been operational since February 2006
- The second Pacific coast cabled observatory, the VENUS Strait of Georgia, was also developed and built by OceanWorks. The first Node and 1 SIIM was deployed in October 2007, and a second Node and 3 additional SIIMs were deployed this year
- OceanWorks is designing and building thirteen Junction Boxes for NEPTUNE Canada based on VENUS SIIMs. NEPTUNE Canada is scheduled for deployment in 2009

# Applicability to Ocean Renewable Energy

- Initial site monitoring – baseline currents, waves, biology, etc.
- Device development and qualification of materials, components, and instruments on or within an ocean energy device
- Device operation – monitoring and control – applies to instruments internal and external to an ocean energy device
- Farm operation – monitoring and control – applies to instruments internal and external to ocean energy devices
- On-going site monitoring – effect of ocean energy device(s) on environment

# Near Shore - Single Device and/or Site Monitoring

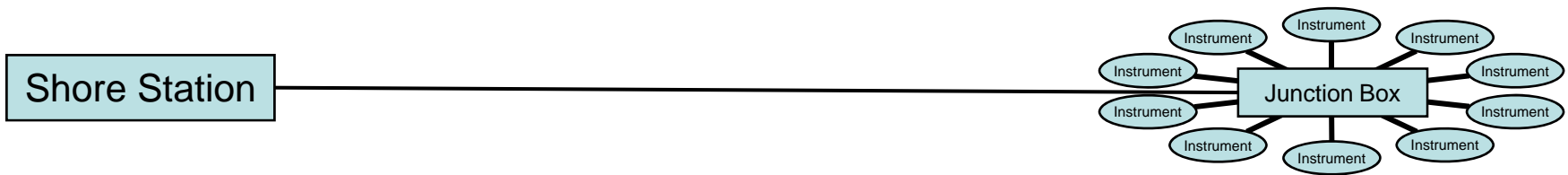

# Near Shore - Two or Three Devices and/or Monitoring Locations

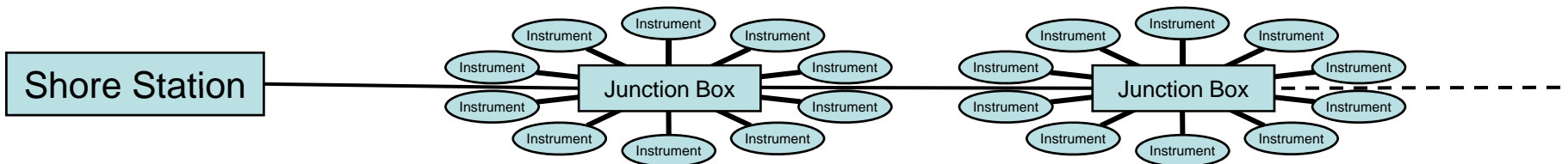

# Multiple Devices – Small Farm and/or Medium Scale Site Monitoring

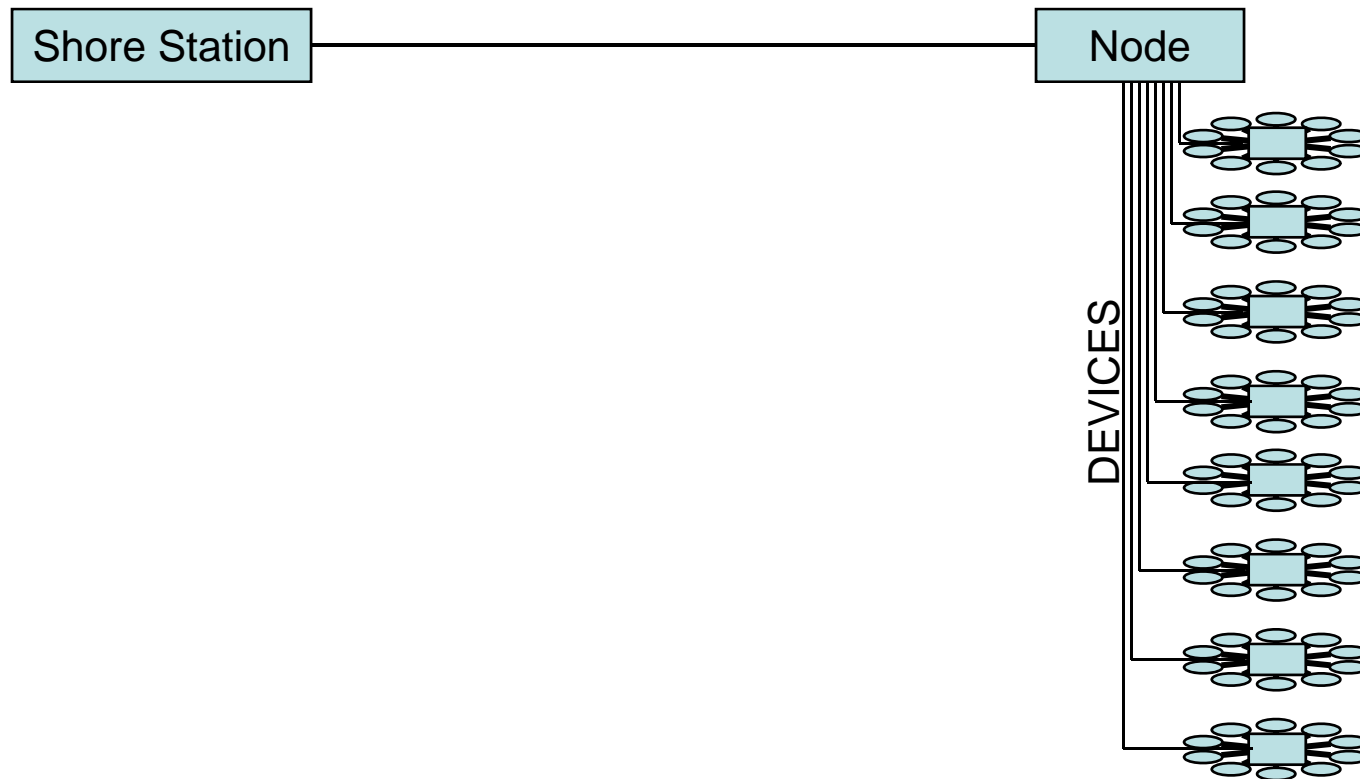

# Multiple Devices – Farm Expansion and/or Large Scale Site Monitoring

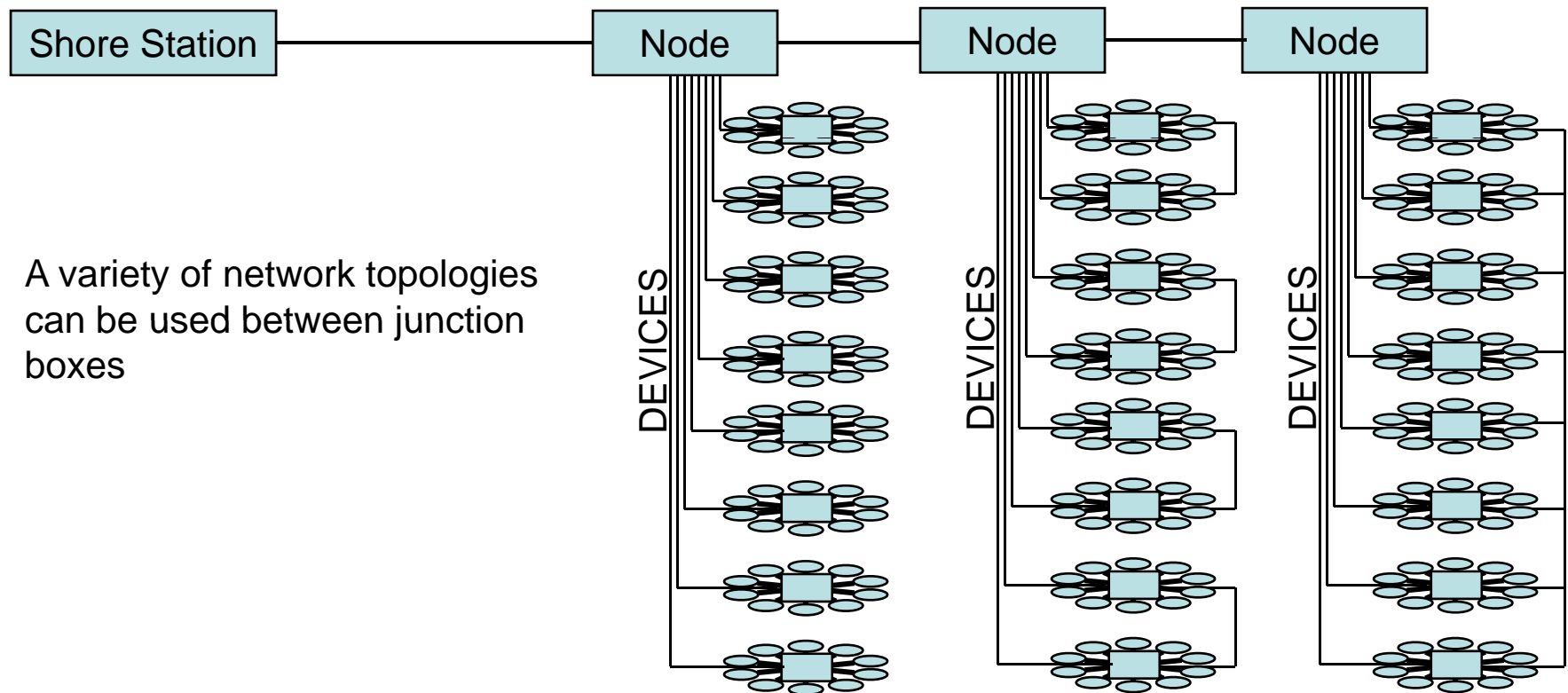

# Multiple Devices – Ring Configuration

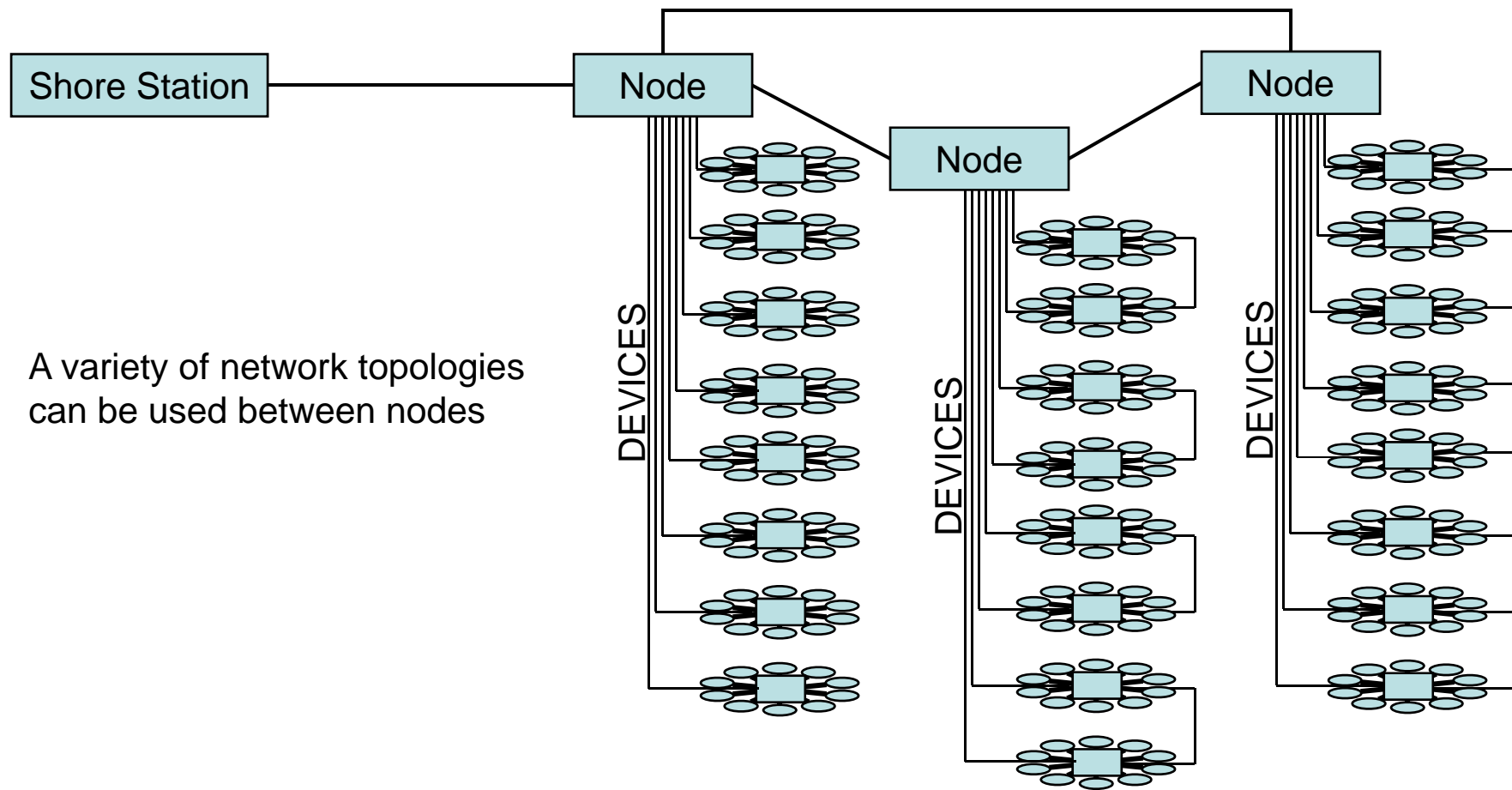

A variety of network topologies  
can be used between nodes

# Relevant Components



Pressure Vessels



Control Computers



Underwater Fiber and Electrical Connectors



Trawl Resistant Frames



Serial Isolation

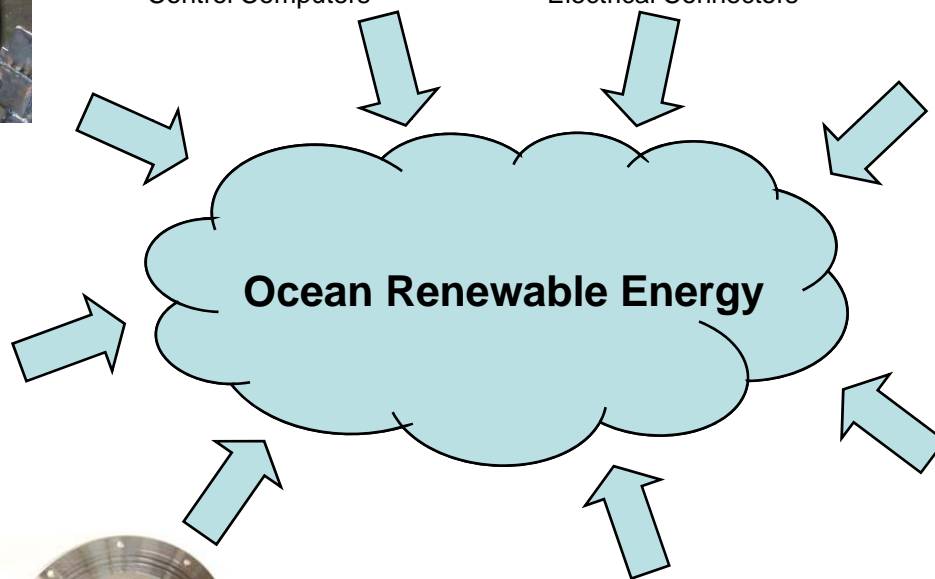

Ocean Renewable Energy

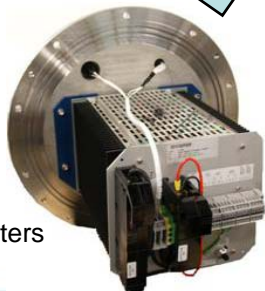

Voltage Converters



Power Distribution and Breakers

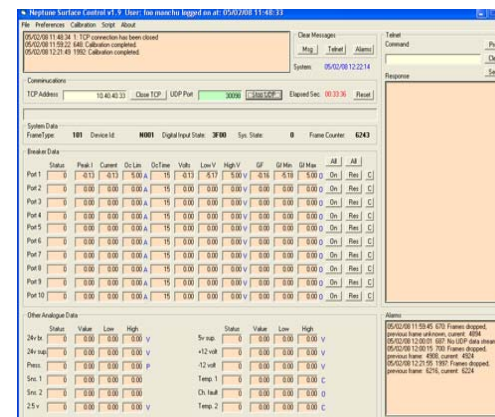

Software

# Backbone

- Twenty year design life with suitable materials
- Fiber Gigabit or 10 Gigabit backbone for high bandwidth
- Standard subsea power and telecom cables
- Utility grade components
- SCADA control of overall system via Ethernet from shore



# EMEC and other Test Beds

- Standard Subsea Cables
  - Armor
  - Power Conductors
  - Signal Conductors
  - Fiber Bundle

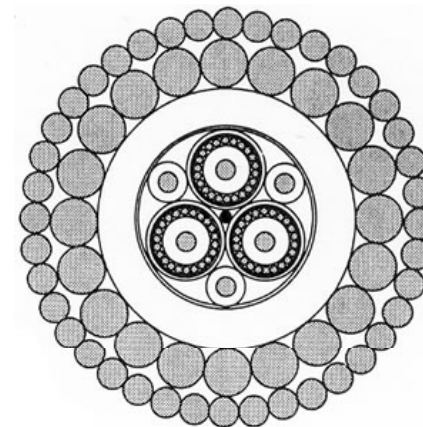

# Distribution Nodes

- Six to Eight Connection Ports for Junction Boxes or Instruments
- Redundancy – can have power and/or signal redundancy
- Reliability – extensive thermal and accelerated life testing
- Modular to allow refurbishment and upgrades
- Graceful failure – a junction box failure cannot cascade into other systems and cannot harm nodes or backbone
- Underwater wet mate or dry mate connectors

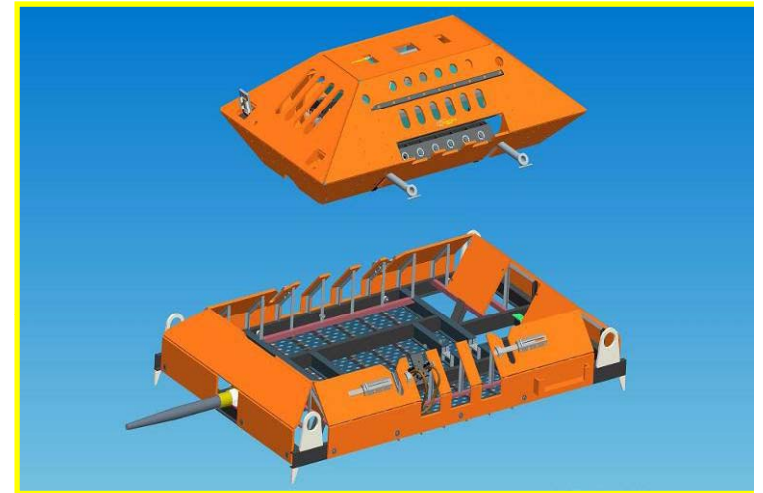

# Junction Boxes

- Six to Ten Instrument Connection Ports
- Redundancy – can have power and/or signal redundancy
- Reliability – extensive thermal and accelerated life testing
- Modular to allow refurbishment and upgrades
- Graceful failure – an instrument failure cannot cascade into other instruments and cannot harm junction boxes, nodes, or backbone
- Underwater wet mate or dry mate connectors

# Junction Box Packaging



Subsea Housing



Embedded



NEMA 4X, IP56 Housing

# Device Servers

- Device Servers connect to Industrial Ethernet Switches
  - Analog
  - Digital
  - Serial
  - Video (MPEG)
- Software resettable signal breakers
  - OWC has found that instrument or connector failures can generate power and ground loops on signal lines. While serial isolation handles transients, it does not handle low level, long term ground fault problems. Signal Line breakers galvanically isolate all signal lines

# Power for Nodes and Junction Boxes

- Up to 600W per instrument
- 3.3VDC to 375VDC
- Can use power from shore or local power from batteries or the device
- Each port can have its own or a shared power supply
- Smart breakers on each port
  - Act as switches and breakers
  - Software configurable and resettable
  - Software monitors voltage, current, and ground faults for each port

# Instrument Types

**Generic – can be used for any or all of the instruments types below  
Digital, Analog, RS232, RS485, Ethernet, Video, and more**

- PLC's
- Switches
- Encoders
- Resolvers
- Depth
- Temperature
- Conductivity
- Salinity
- Cameras
- Lights
- Pan and Tilts
- Power monitors
- Servo valves
- Linear actuators
- Rotary actuators
- Accelerometers
- Relays
- Proximity sensors
- Strain gauges
- Compasses
- Acoustic Dopplers
- Sonars
- Hydrophones
- Single board computers
- Pressure sensors
- Inclinometers
- Leak Sensors
- Solenoids
- Data collectors
- Level gauges
- Battery chargers
- Timers
- Time sync, etc.

# Prequalification

- Applies to instruments, junction boxes and nodes
- OWC has found that off the shelf instruments fail more often than infrastructure components
- Test bed in the lab (wet/dry under various environmental conditions)
- VENUS can be used as a test bed for qualification of instruments and components in the ocean

# Testing...Testing...Testing



Cable Simulation



Endurance



Thermal



Hydrostatic

# Certification

- **Commercial Certifications:**
  - ABS, DNV, Lloyds, Others as Required
- **Military Certifications:**
  - NAVSEA P-9290
  - NAVSEA MAN 010
- **Manned / Unmanned Hydrostatic Testing**



- **ISO 9001 Quality System**

- 3rd Party Certificate of Registration
  - OWC registered under QMI
  - OWI registered under DNV
- OWC audited by USN to NAVSEA P-9290 Standards for Manned Submersibles

# Some Observatory Web Sites

- VENUS – [www.venus.uvic.ca](http://www.venus.uvic.ca)
- LEO-15 – [www.marine.rutgers.edu/mrs/LEO/LEO15](http://www.marine.rutgers.edu/mrs/LEO/LEO15)
- Bonne Bay – [www.bonnebay.mun.ca](http://www.bonnebay.mun.ca)
- NEPTUNE Canada – [www.neptunecanada.ca](http://www.neptunecanada.ca)
- MARS – [www.mbari.org/mars](http://www.mbari.org/mars)
- OOI – [www.ooi.washington.edu](http://www.ooi.washington.edu)
- ESONET – [www.esonet-emso.org](http://www.esonet-emso.org)
- OceanWorks – [www.oceanworks.com](http://www.oceanworks.com)

# THANK YOU

OceanWorks International Corporation  
#120 – 6741 Cariboo Road  
Burnaby, BC, Canada V3N 4A3  
Phone: 604-415-0088

OceanWorks International, Inc.  
11611 Tanner Road  
Houston, Texas, USA 77041  
Phone: 281-598-3940