

North Atlantic Energy Structures

OREG Fall Symposium
October 19 – 20, 2005

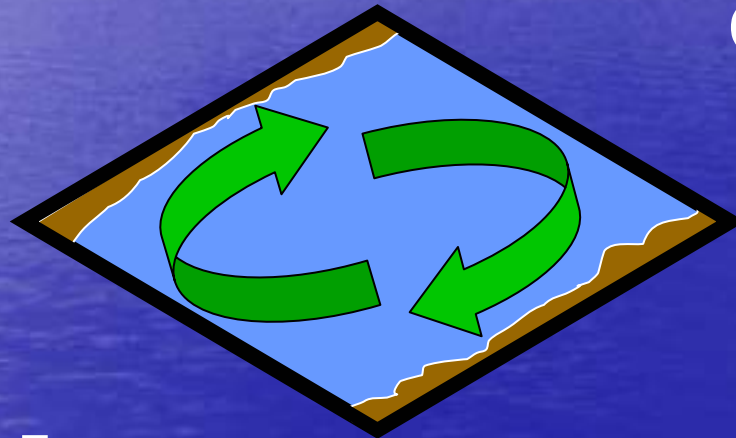

Steven Campbell, P.Eng

President - North Atlantic Energy Structures

Dr. Ahmed Derradji

Senior Research Officer - NRC

Presentation Overview



- Green Power Tidal Energy from the Belle Isle Straits
- The NAES Design
- Numeric Model Power Gen
- Slab-Ice Simulation Study: NRC
- Converting Cyclic Tide into Steady State Power
- Conclusions – Path Forward

The Belle Isle Straits

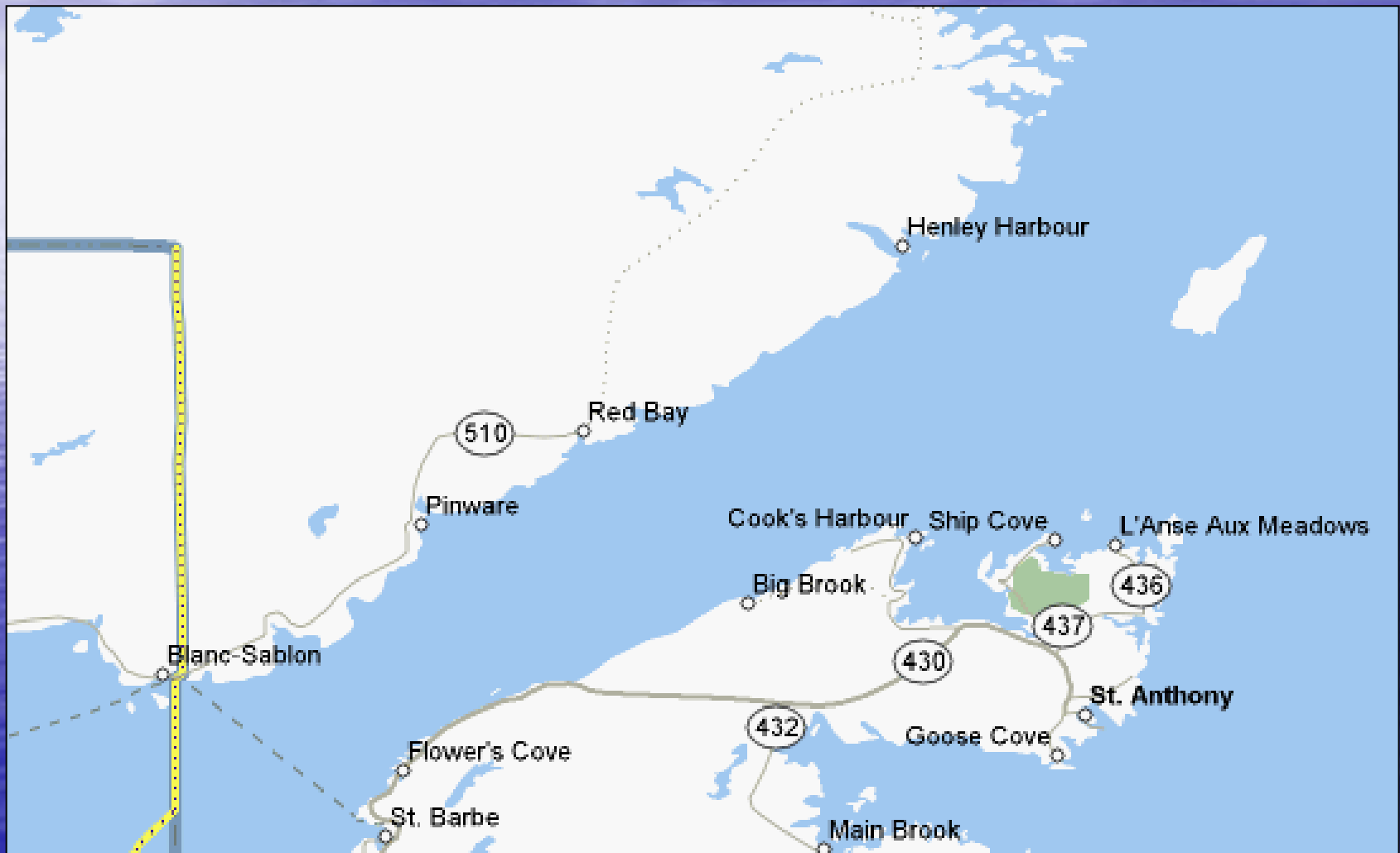

Straits of Belle Isle

- High-Speed Water Flow 5 knots
- Relatively Shallow (60-80 meters)
- No Mud on the Bottom
- Access to Large Quantities of Rock
- 1000 Km from Montreal

Design Constraints

- Harsh Environment: High Velocity Tides, High-Winds, Small Icebergs, Slab Ice,
- Seasonal Work Window
- Pristine Environment

NAES Tidal-Power Energy Generation

- Green-Power Energy Forever
- Seabeds as a Bridge or Fixed Link
- Foundations for Windmills
- Paddlewheels in Caissons - Free-stream Flow
- Water Flow Converted to Torque Energy
- Cyclic Tide to Steady State Power
- Patented NAES

Paddlewheels

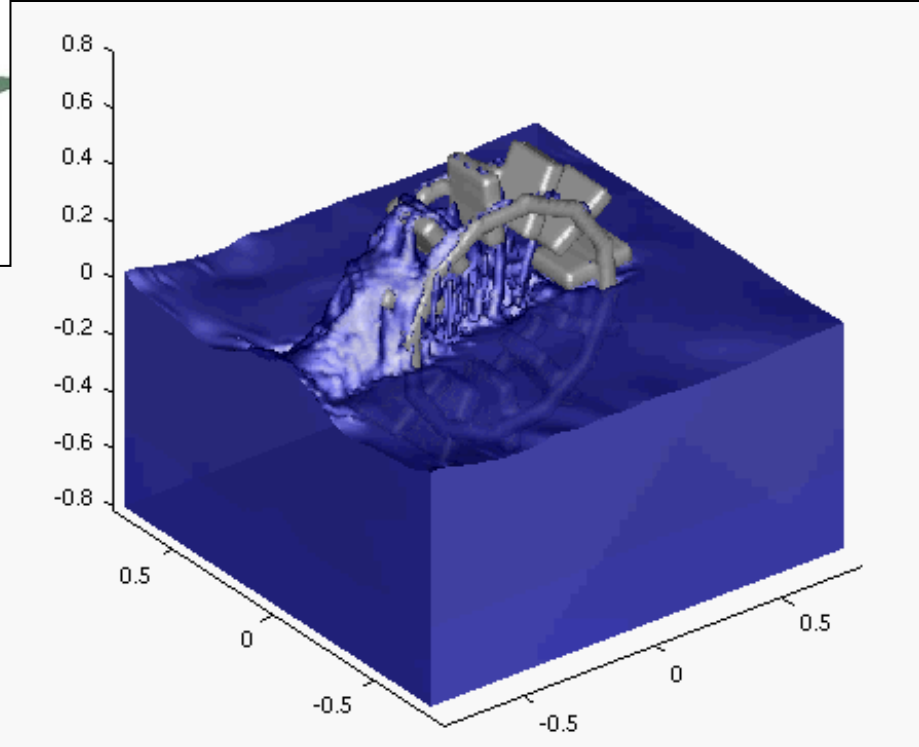
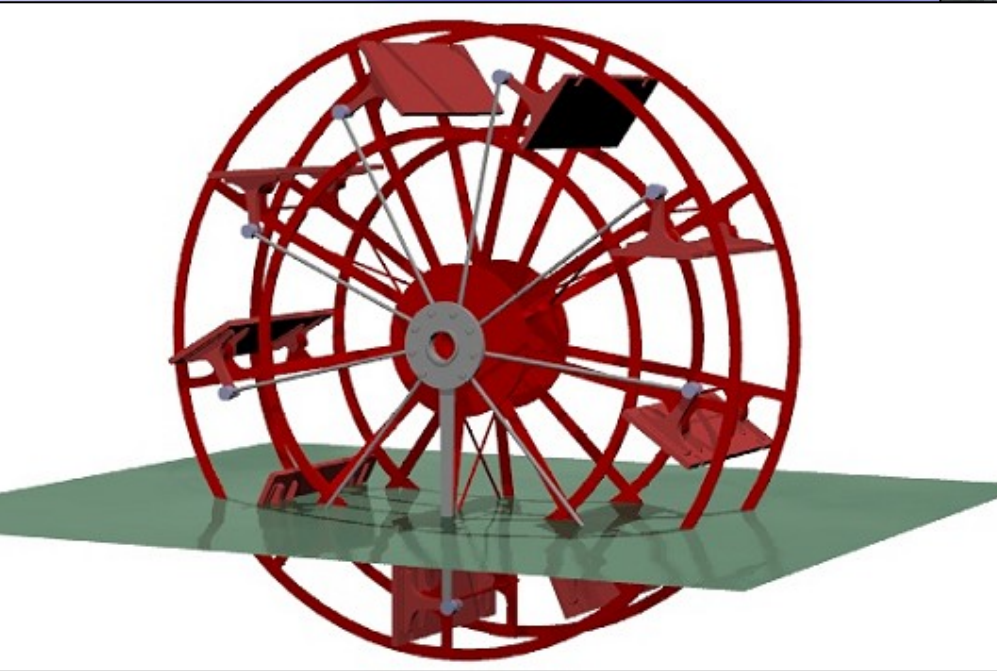

4000 years old

Force of Water Flow to Power

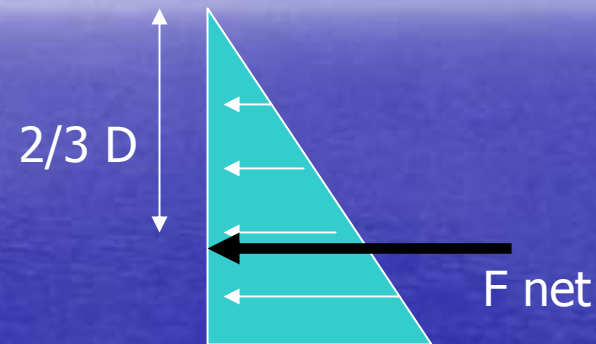
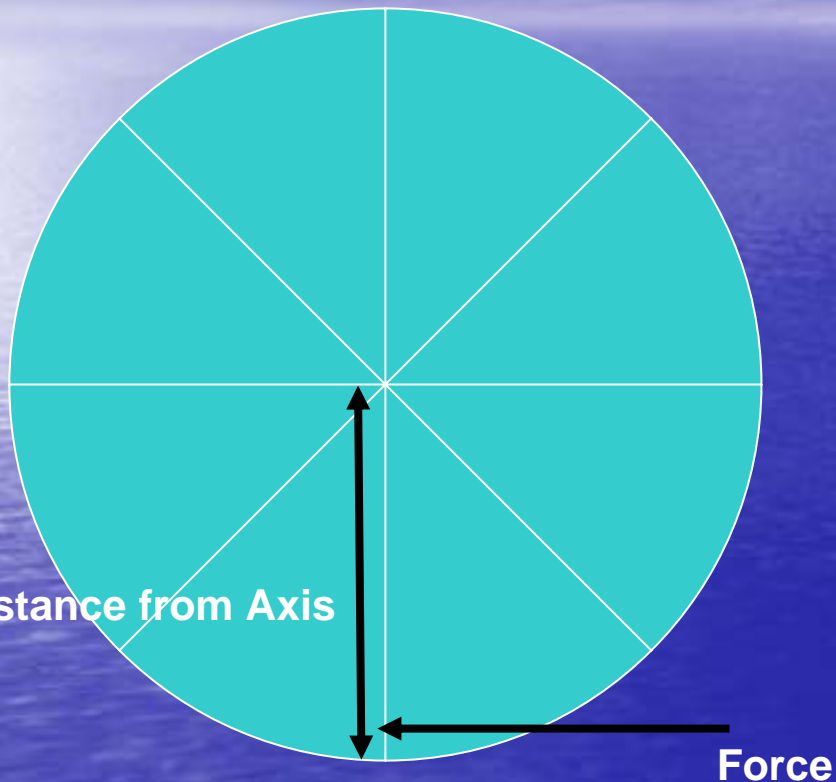

$$\text{Torque} = \Sigma \text{ Force} \times \text{Distance}$$

$$\text{Power} = \text{Net Force} \times \text{Velocity}$$

Caisson Design

- 20 Paddlewheels / Caisson
- Cemented to Rock Weir
- 50m Span for Bridge-Beams
- Base for Wind-Power Generators
- Paddlewheels 12 - 30m Diameter

20 Chamber Caisson

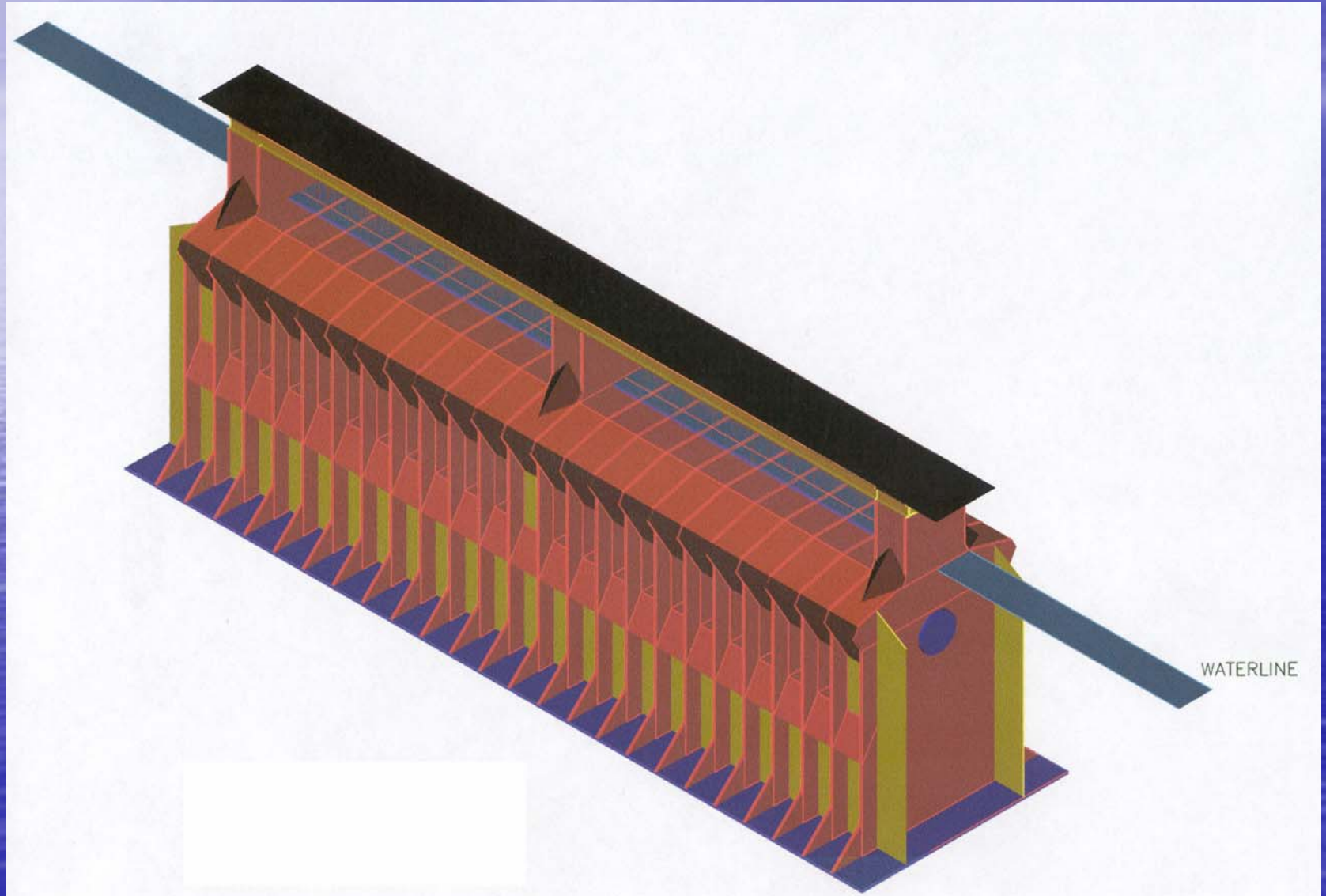

Principles of the Proposed Design

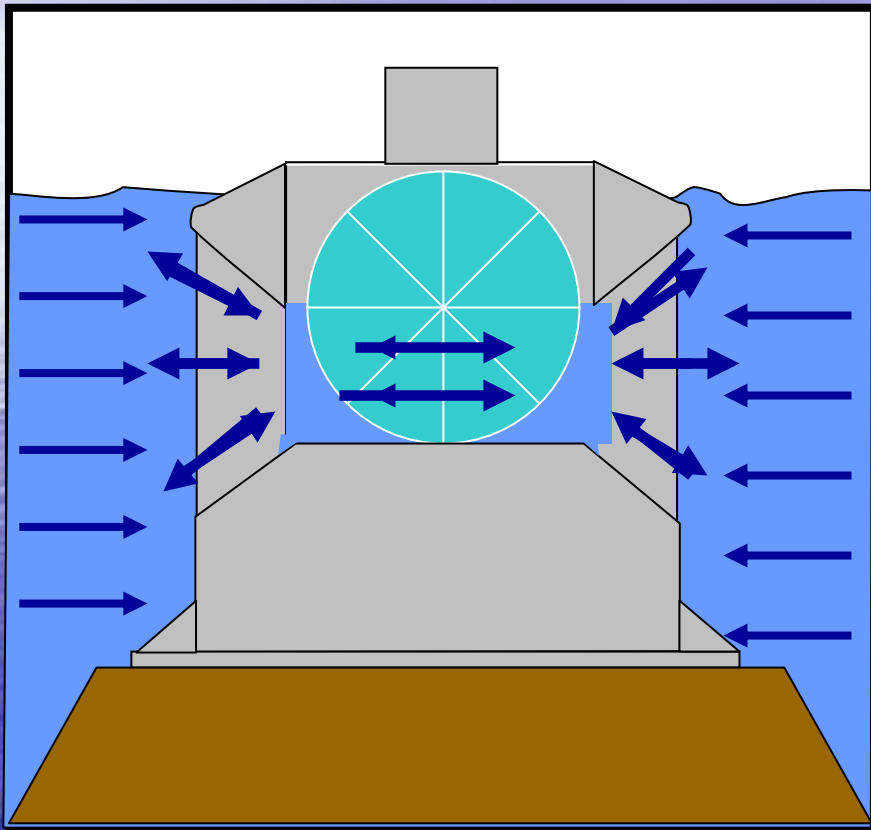

- Paddlewheel Protected from Surface Forces
- Iceberg / Slab Ice Resistant
- Portals Below Wheel Axis
- Water-Free Upper Chamber (Air Pressure)
- Bi-Directional Power Generation (Water Sails)

Installation Sequence

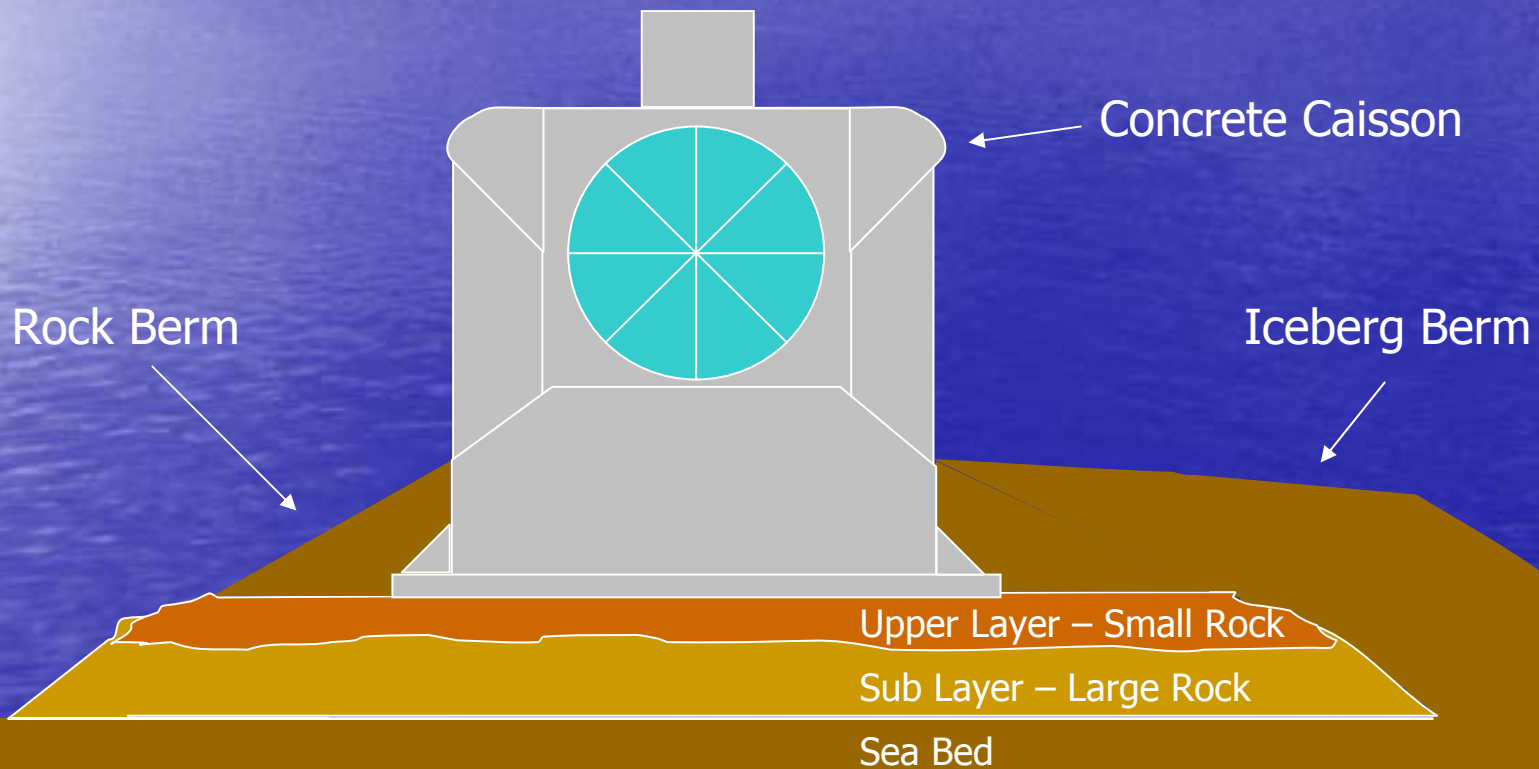

Numerical Simulation

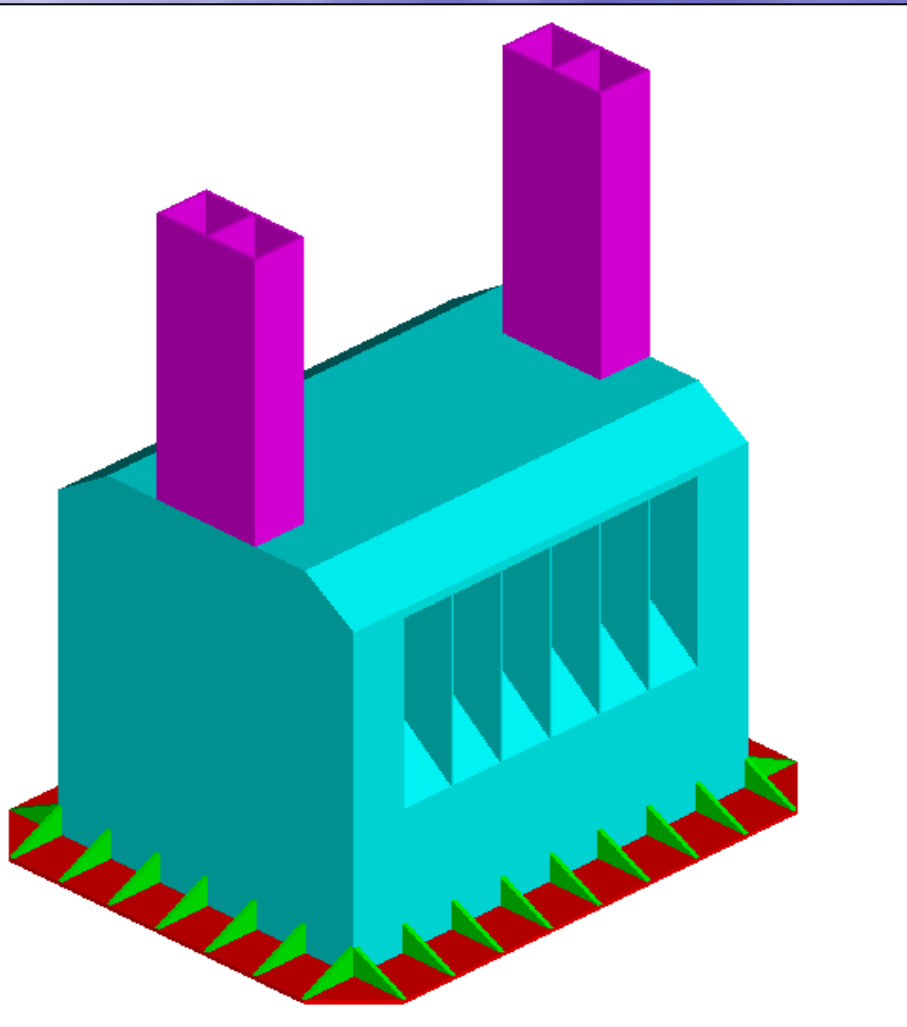

- Hydrodynamic Study (Flow – 3D)
- Six Chamber Caisson
- Conditions:
 - 40m depth
 - 18m diameter wheel
 - 5 x 10m Portals
 - Current speed 1.25 m/s (2.5 knots)

Torque on Each of 3 Turbines in Tidal Energy Chamber

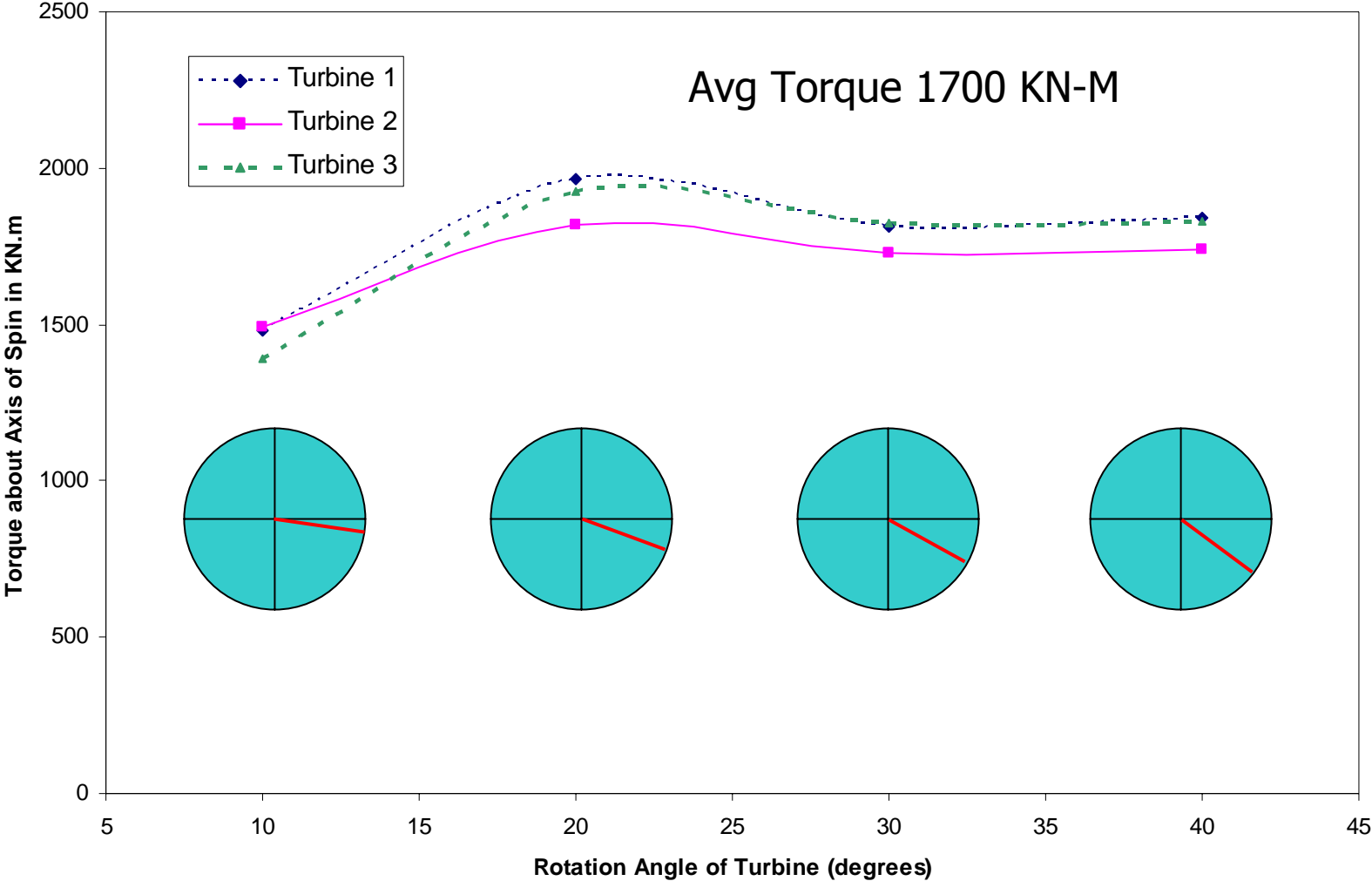

Force on Each of 3 Turbines in Tidal Energy Chamber

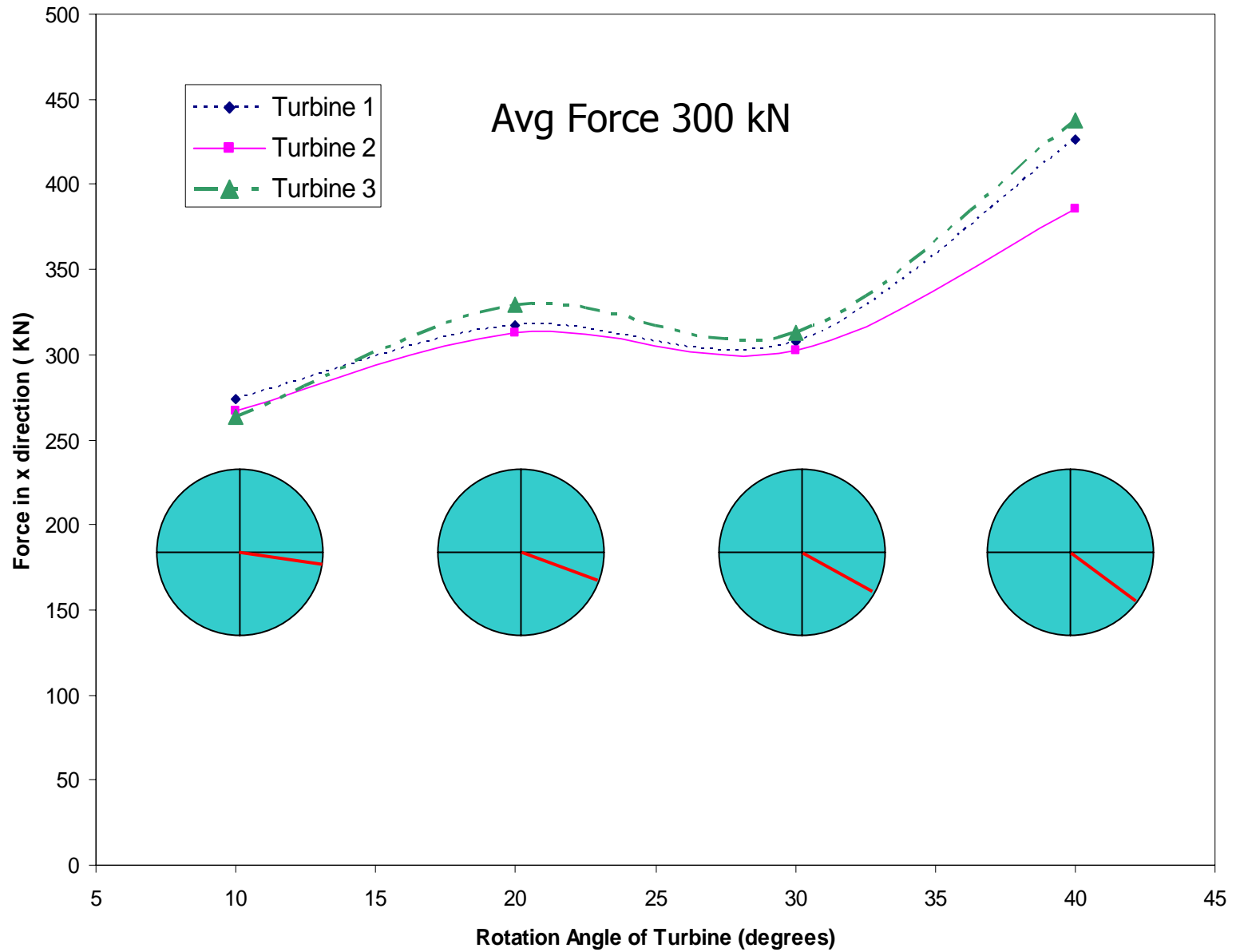

Power Generation Results

$$\begin{aligned} \text{Power} &= \text{Force} \times \text{Velocity} = 300 \text{ kN} \times 2 \text{ m/s} \\ &= 600 \text{ kilowatts / wheel} \end{aligned}$$

$$\begin{array}{rcl} 20 \text{ Paddlewheels per Caisson} & = & 12 \text{ MW} \\ \text{Wind Power Generator} & + & \underline{3 \text{ MW}} \\ & & \underline{15 \text{ MW}} \end{array}$$

$$70 - 80 \text{ Caissons / Fence} = 1.2 \text{ GW}$$

Harnessing the Power of the Belle Isle Straits

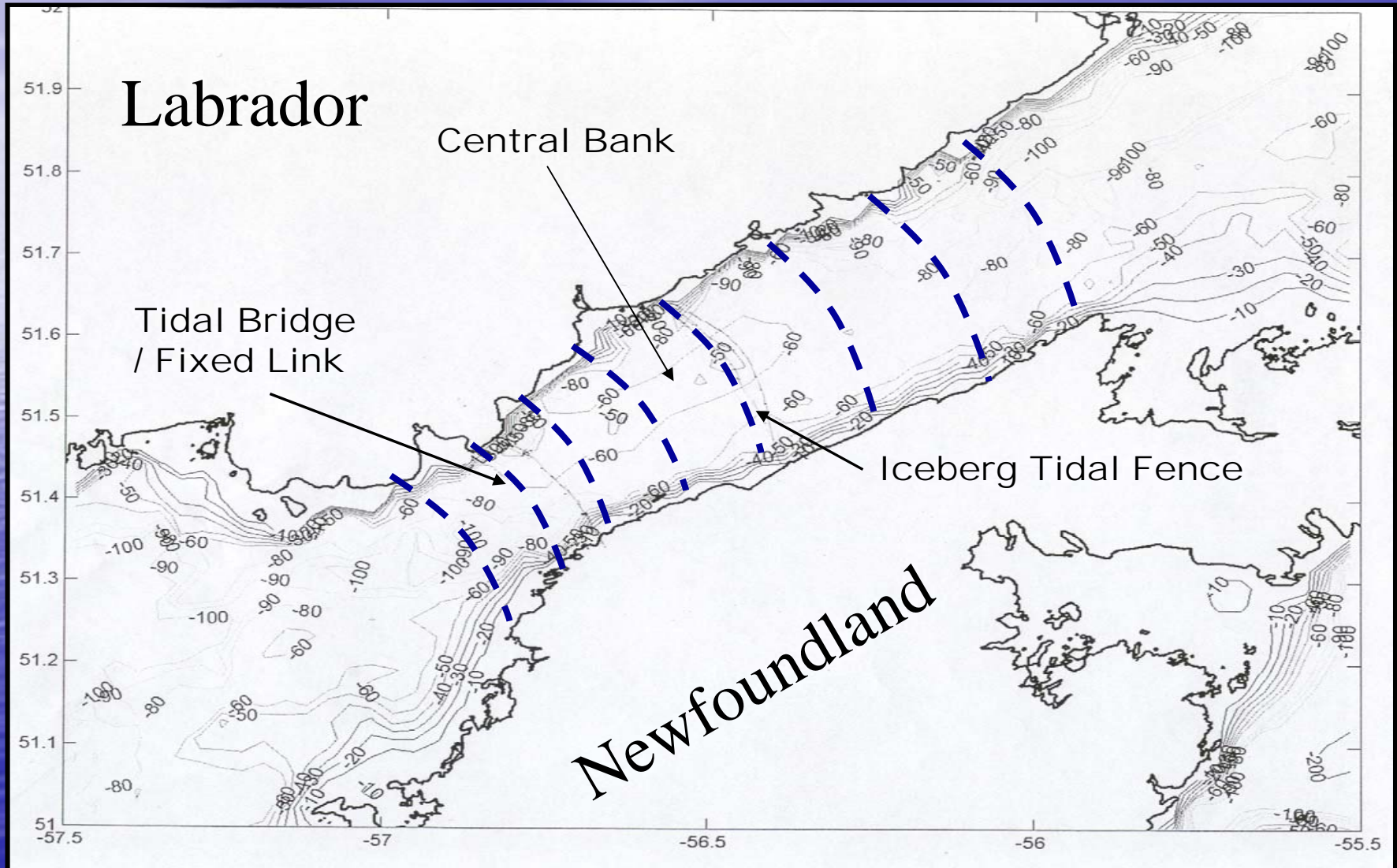

Cyclic Tidal Power

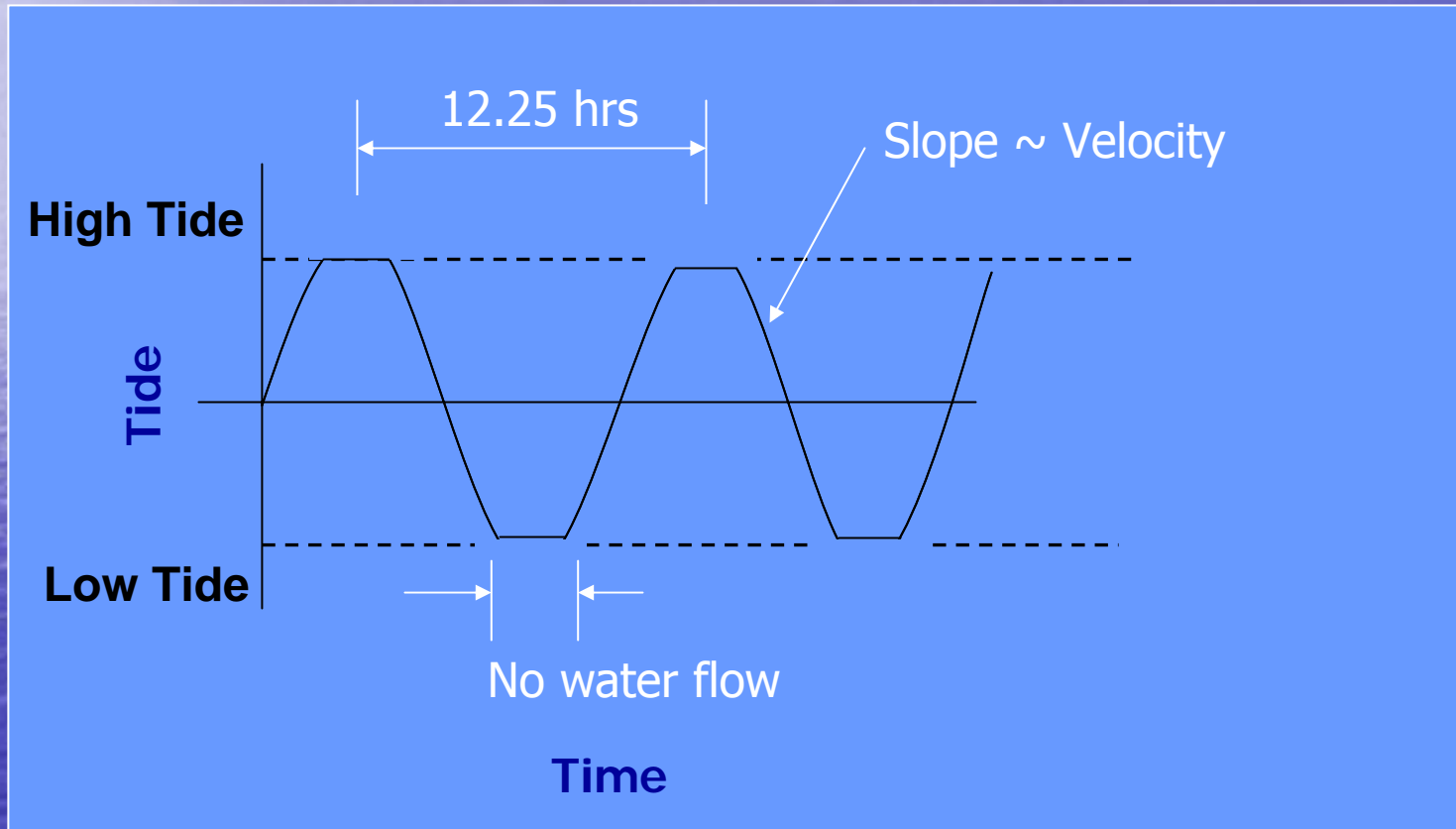

Cyclic to Continuous Power

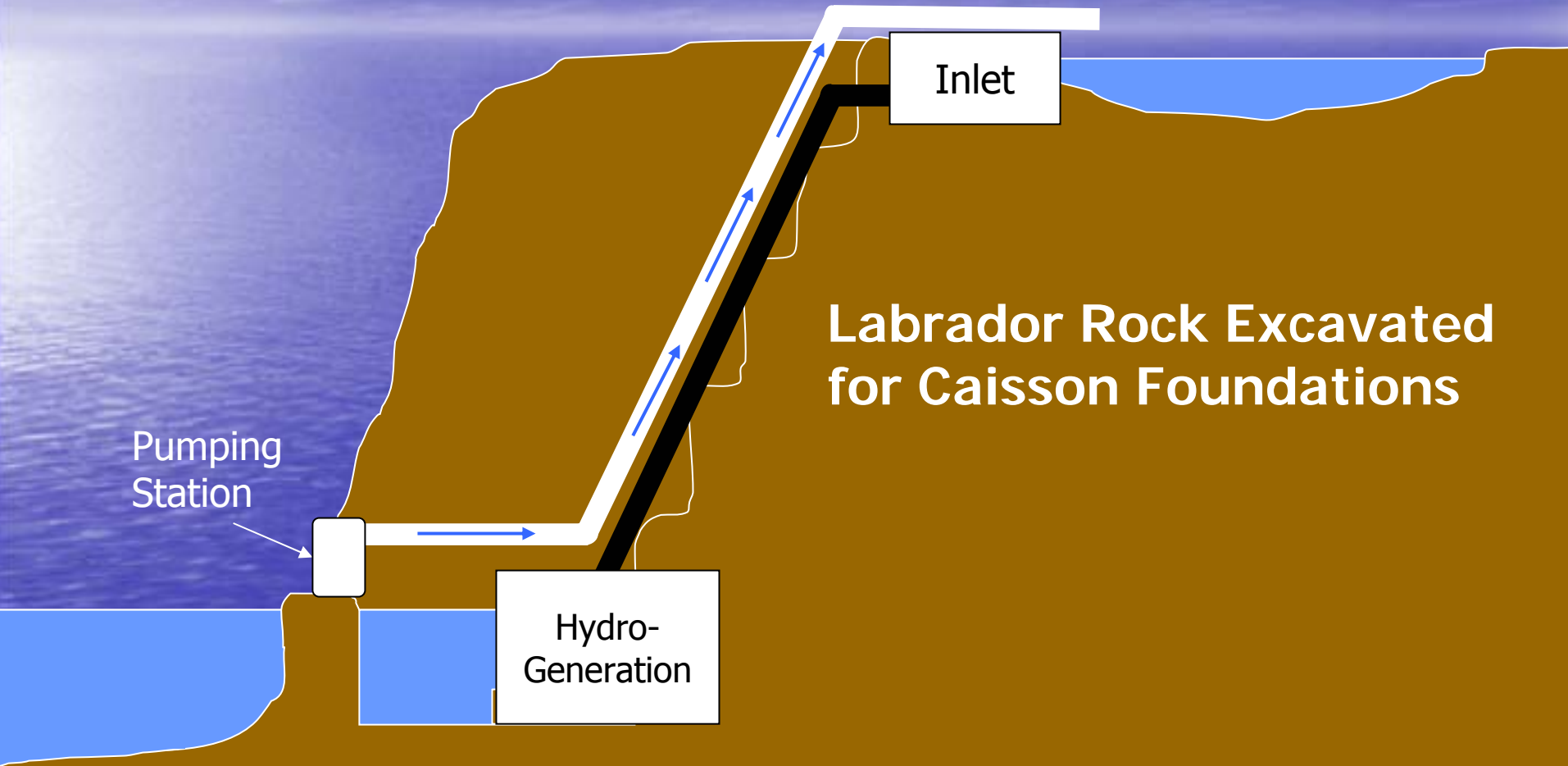

Slab Ice Simulation Study

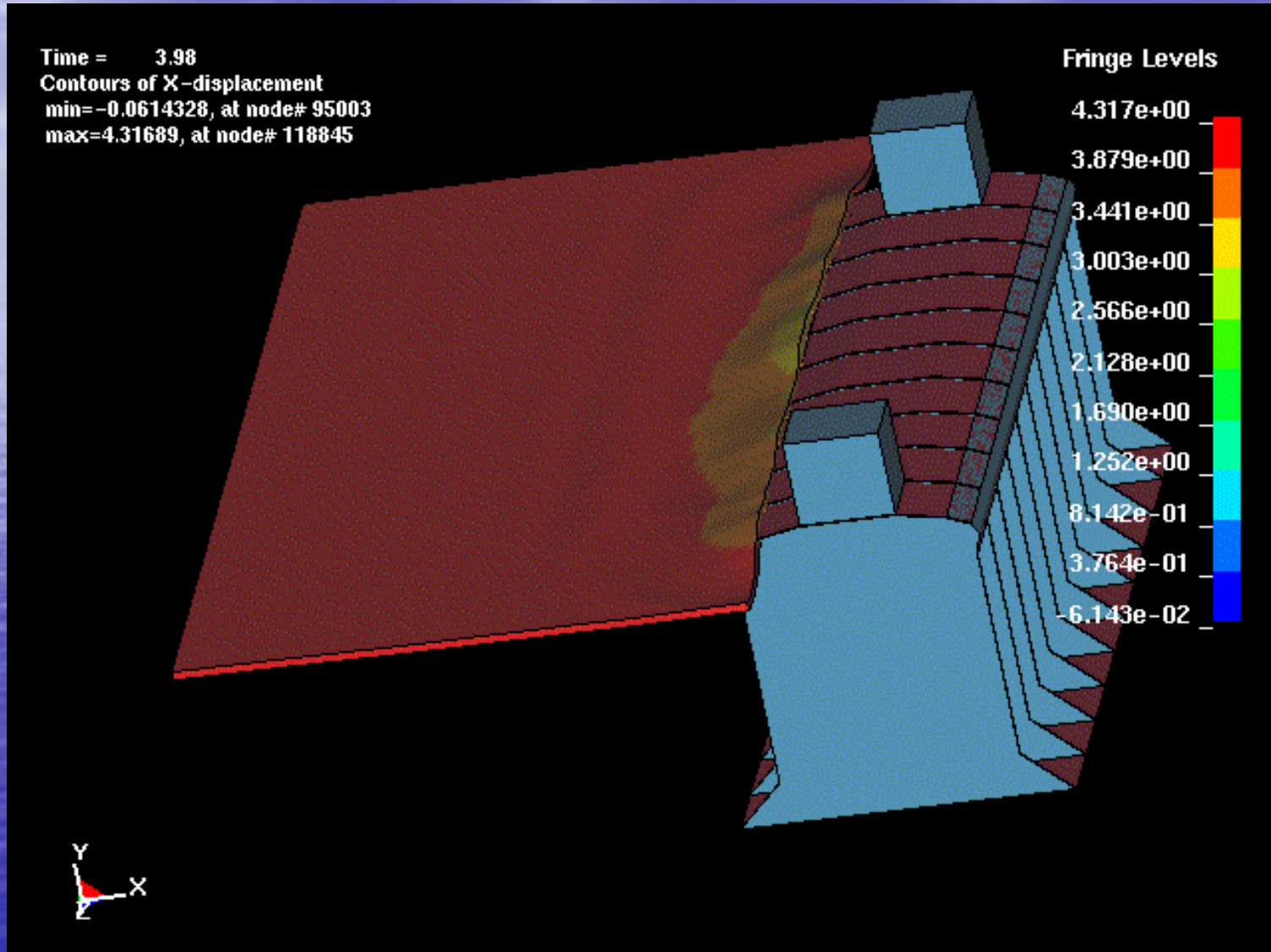

Time = 0
Contours of Max Prin Dev Stress
max ipt. value
min=0, at elem# 891
max=0, at elem# 891

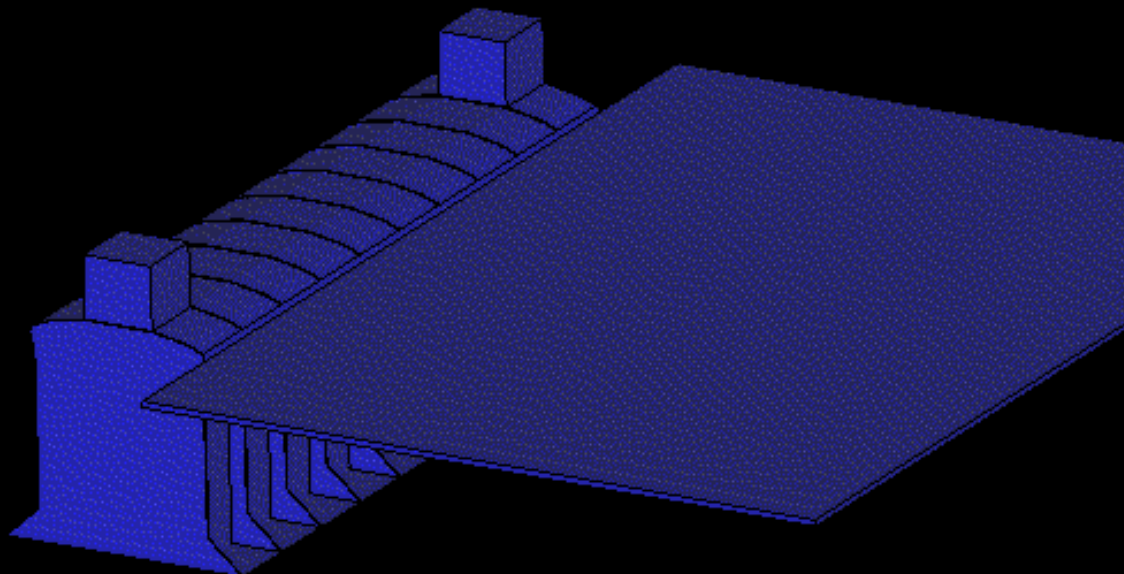

Fringe Levels



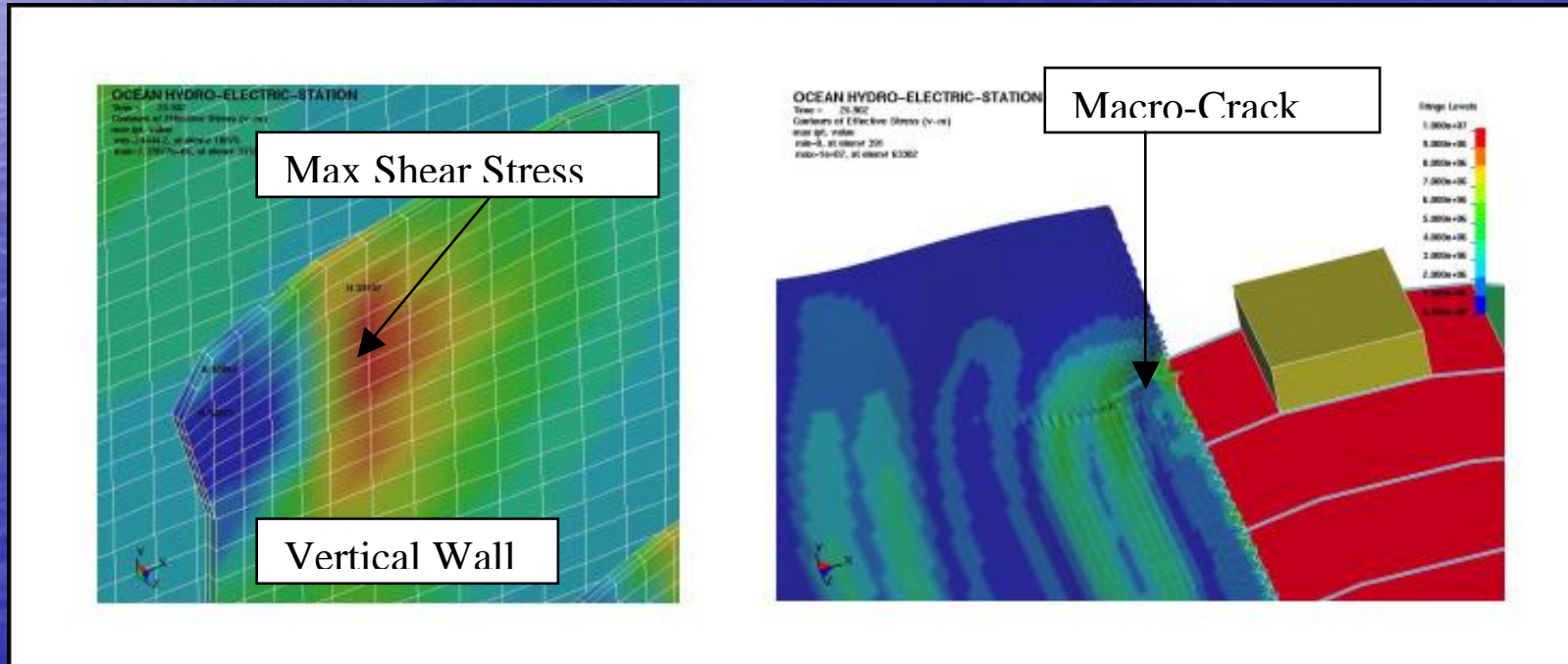
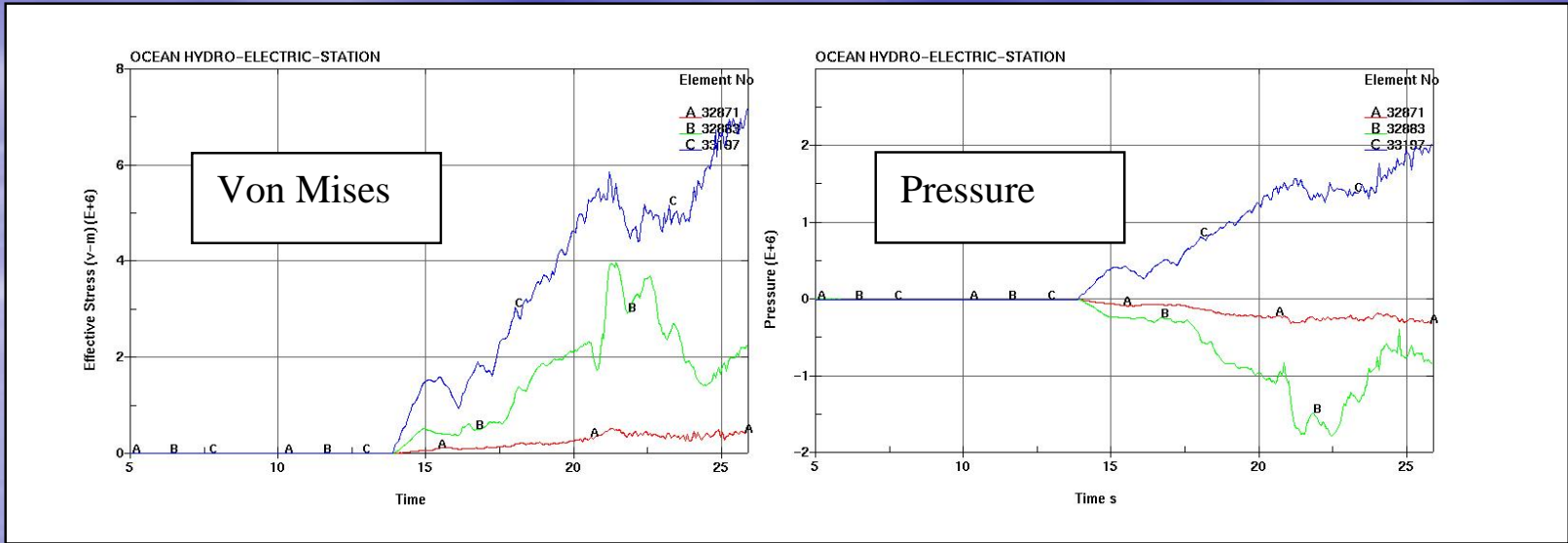

Ice Load Simulation Results

- Pressure on Ice Diverter 2.5 MPa
- Shear Stress in the Walls 7.0 MPa
- 50 MPa Reinforced Concrete
- More Research Work Required
 - Will reduce structural loads

Development Path

- Front End Engineering Design
 - Environment Loads – Current / Ice / Waves
 - Concrete & Foundation Design
 - Power Generation Design
 - Wind-Power Potential
 - Cost Estimate per Caisson

Development Path

- Model Testing
 - Design and Construction
 - Flume Tank Test (Marine Institute)
 - Hydrodynamic & Ice Impact Testing (IOT)
- Environmental Study
- Financing for Pilot Project

Conclusions & Path Forward

- Straits of Belle Isle - Green-Power Energy
- 10 GW Plus - Canadian Economic Wealth
- Seconds as a Fixed Link or Bridge
- Many Other NAES Green Power Projects
- Seed Financing for R&D Required